

Hydraulic Inspection

Test Pressure	SHELL	2.10Mpa
	SEAL	1.54Mpa
Temperature	AIR	0.60Mpa
	Medium	5205°C Water, Steam, Oil etc

Technical Standard

Design	JIS F7425
Face to Face	JIS B2002
Flange End	JIS B2220
T&Rressure	JIS B2073
Inspection&Test	JIS F7400

Material List

17	Disc	Cast Brass	C3771BD
16	Seat Ring	Cast Brass	C3771BD
15	Baffle Ring	Cast Brass	C3771BD
14	Stud Bolt	Steel	SS400
13	Packing	Graphite	
12	Stud Bolt	Steel	SS400
11	Packing Gland	Cast Brass	C3771BD
10	Nut	Steel	SS400
9	Screw Nut	Steel	SS400
8	Cushion	Steel	SS400
7	Nut	Steel	SS400
6	Pin	Stainless Steel	SS410
5	Handwheel	Cast Iron	FC200
4	Stem	Brass	H62
3	Bonnet	Cast Brass	C3771BD
2	Seat Ring	Non-Asbestos	
1	Body	Cast Brass	C3771BD

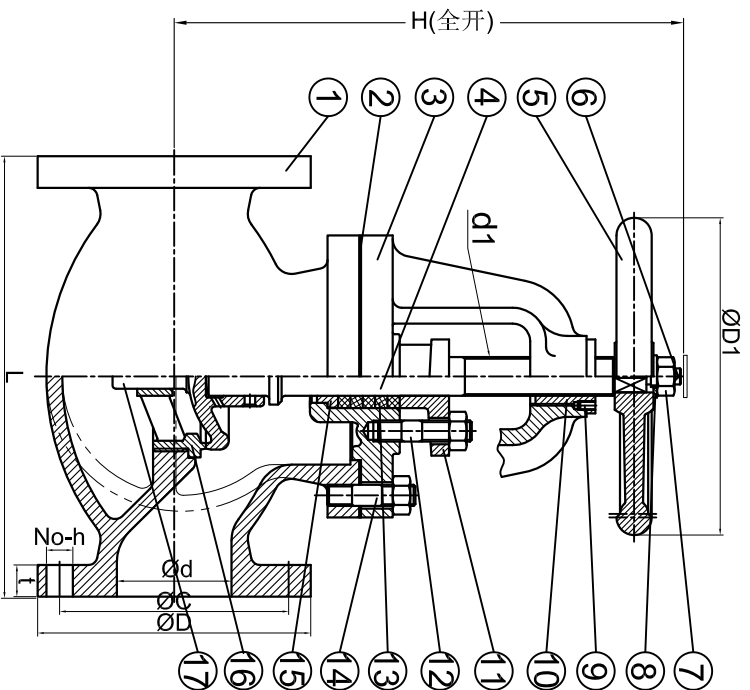

MAIN DIMENSIONS

SIZE	d	L	D	C	No-h	t	H	D1	Weight Kgs	CODE
50A										
65A	65	270	175	140	4*19	22	310	200	28.70	750232
80A										
100A										
125A										
150A										
200A										
250A										
300A										
350A										
400A										

Product Name	CAST BRASS FALNGED GLOBE VALVE		
	JIS F7307 10K		
Drawing NO.	CHK'D	CHK'D	APP'D
RH-GLVV-0568	Tom	Cathrine	Coco



QINGDAO RONGHANG MARINE VALVE
MANUFACTURING CO.,LTD

www.marine-valve.com